

# I N F I N I T E



## S Y S T E M S

## VLF 1 HPX ND

High Efficiency Very Low Frequency Speaker System, Short Horn Rectangular 1" MDF enclosure with Quasi Direct Radiating, Push Pull configuration, loaded with Dual 18" High Output Transducers, 1" thick Natural Rubber Isolation feet. Grille material shall be a robust 18-gauge 316L Stainless Steel, Neutrik Connector in recessed pocket. Standard finish color is textured black and is also available in any custom color, 5-year Limited Commercial Warranty.

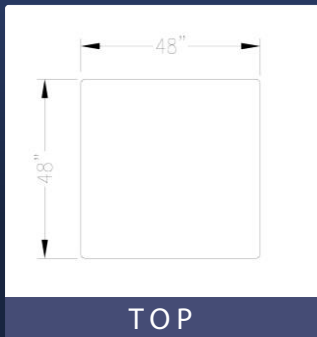

TOP

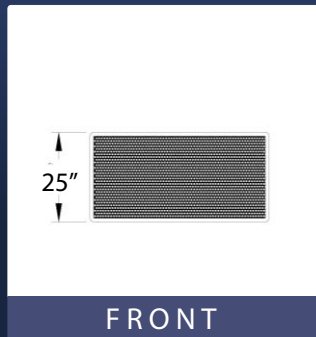

FRONT

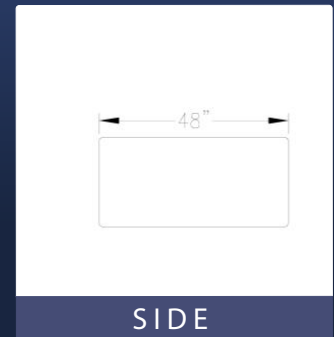

SIDE

### TECHNICAL DATA

Utility	Very Low Frequency
Configuration	Dual 18" Vented, Horn Loaded
Nominal Impedance	Dual 8 ohm
Rated Power RMS	3600 W
Peak Power	7200 W
Sensitivity 1W/1M	103 dB
Applied Range	24Hz to 120 Hz
Components	Dual 18" Transducers, 4.5" Voice Coils
Connectors	NL-4 Recessed Pocket
Net Weight	220 lbs
Finish Colors	Black or Custom
Grille Protection	316L Stainless
Warranty	60 Months Commercial Warranty
Dimensions	48" W x 48" D x 25" H

### WP WEATHER PROTECTED VERSION

- Constructed of Treated Exterior Composite wood panel, which is vermin, termite and mold resistant, without sounding like plastic or fiberglass.
- 316L Stainless Steel Grille for maximum corrosion resistance in the harshest environments.
- 1/4" acoustically transparent foam water stop layer.
- 100 micron 316L Stainless Steel Mesh for insect resistance in outdoor use within landscape environments.
- Weatherized component treatment for long term reliability.
- Watertight junction box for secure connections and vandal resistance on larger properties.
- All Stainless Steel Hardware for reliable, long term outdoor installation.