

I N F I N I T E



S Y S T E M S

VLF115 HPX ND

A Compact Very Low Frequency Speaker System, Rectangular MDF enclosure for reduced resonance. This system is loaded with a single 15" Neodymium Magnetic High Efficiency Transducer with a 4.5" voice coil and a specially treated coated cone. Grille material shall be a robust 18-gauge 316L Stainless Steel. Recessed Steel Input Panel with Neutrik Connector. Standard finish color is textured black and is also available in any custom color, 5-year Limited Commercial Warranty.

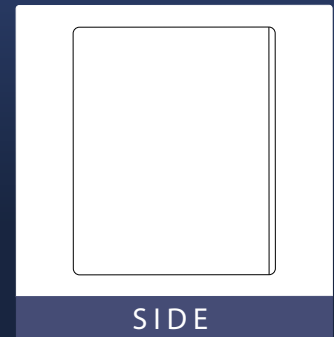
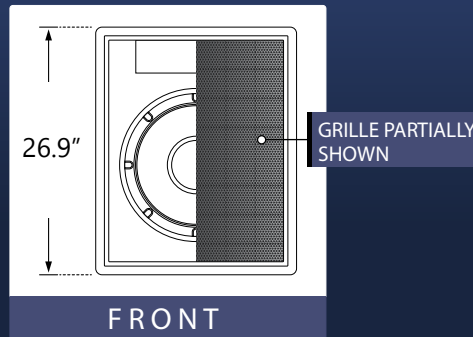
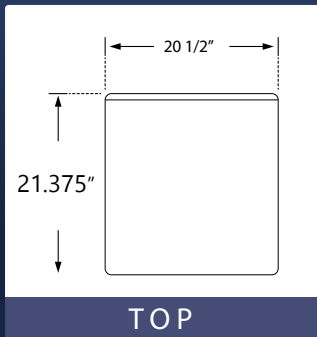
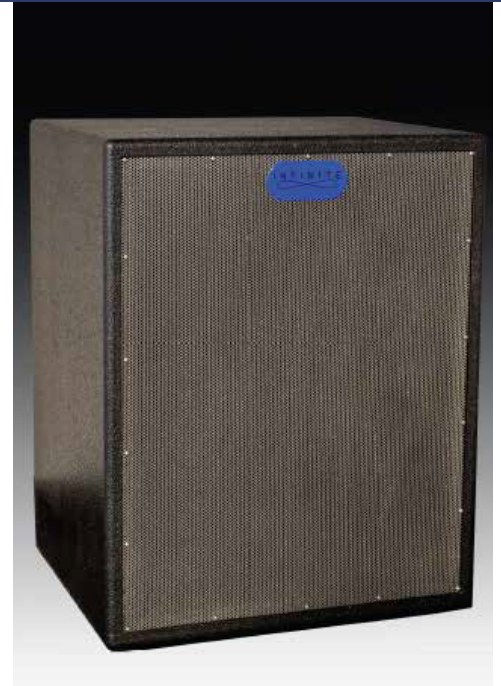

TECHNICAL DATA

Utility Configuration	Very Low Frequency Vented Single Transducer
Nominal Impedance	8ohms
Rated Power RMS	1500W
Peak Power	3000W
Sensitivity 1 W/1 M	96.3 dB
Applied Range	30 Hz to 120 Hz
Components	15" Transducer, 4.5" Voice Coil
Connectors	NL-4 Recessed Pocket
Net Weight	69 lbs / 31.3 kg
Finish Color	Black or Custom
Grille /Protection	316L Stainless Steel
Warranty	60 Months Limited Commercial
Dimensions (W x D x H)	20 1/2"Wx21 1/4" Dx25 1/2" H

WP WEATHER PROTECTED VERSION

- Constructed of Treated Exterior Composite wood panel, which is vermin, termite and mold resistant, without sounding like plastic or fiberglass.
- 316L Stainless Steel Grille for maximum corrosion resistance in the harshest environments.
- 1/4" acoustically transparent foam water stop layer.
- 100 micron 316L Stainless Steel Mesh for insect resistance in outdoor use within landscape environments.
- Weatherized component treatment for long term reliability.
- Watertight junction box for secure connections and vandal resistance on larger properties.
- All Stainless Steel Hardware for reliable, long term outdoor installation.