

I N F I N I T E



S Y S T E M S

VLF 215

A Compact Very Low Frequency Speaker System, Rectangular MDF enclosure for reduced resonance. This system is loaded with dual 15" High Efficiency Transducers, 4" voice coils and specially treated cones. Grille material shall be a robust 18-gauge 316L Stainless Steel. Recessed Steel Input Panel with Neutrik NL-4 Connector. Standard finish color is textured black and is also available in any custom color, 5-year Limited Commercial Warranty.

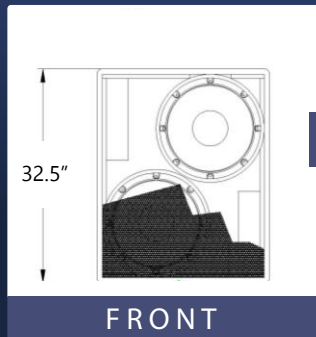
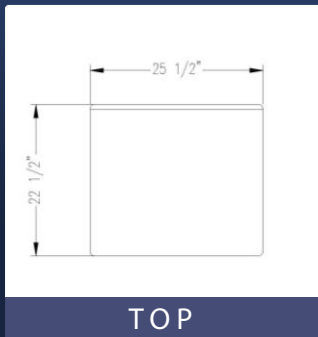
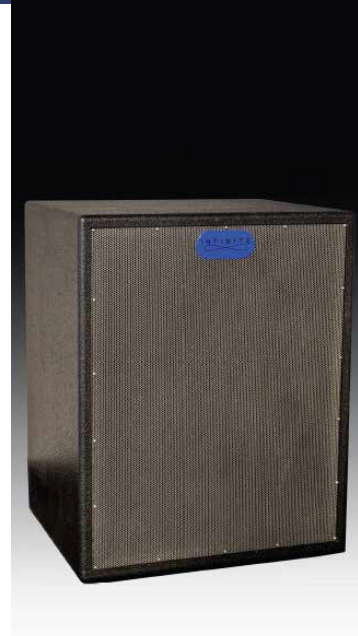

GRILLE PARTIALLY SHOWN

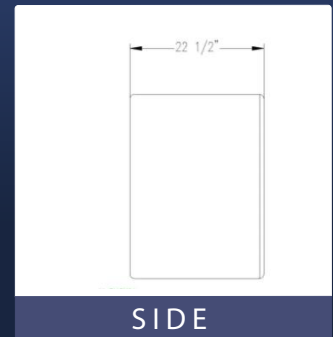

TECHNICAL DATA

Utility	Very Low Frequency
Configuration	Dual Transducer
Nominal Impedance	Dual 8 ohm
Rated Power	1000 W
RMS Peak Power	2000 W
Sensitivity 1W/1M	99 dB
Applied Range	30 Hz to 120 Hz
Components	Dual 15" Transducers, 4" Voice Coils
Connectors	NL-4
Net Weight	170 lbs / 77.1 kg
Finish Color	Black or Custom
Grille/Protection	316L Stainless Steel
Warranty	60 Months Limited Commercial
Dimensions (W x D x H):	25 1/2" W x 22 1/2" D x 31 3/4" H

WP WEATHER PROTECTED VERSION

- Constructed of Treated Exterior Composite wood panel, which is vermin, termite and mold resistant, without sounding like plastic or fiberglass.
- 316L Stainless Steel Grille for maximum corrosion resistance in the harshest environments.
- 1/4" acoustically transparent foam water stop layer.
- 100 micron 316L Stainless Steel Mesh for insect resistance in outdoor use within landscape environments.
- Weatherized component treatment for long term reliability.
- Watertight junction box for secure connections and vandal resistance on larger properties.
- All Stainless Steel Hardware for reliable, long term outdoor installation.